

RA-2 150 DF TECHNICAL SHEET AIR KNIVES DOUBLE FLOW



OPERATING PRINCIPAL

Surrounding air

Amplified air output
(Compressed air input
+ surrounding air)

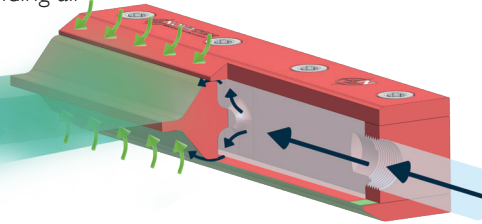

Compressed
air input

Economical
UP TO
95%
SAVINGS IN AIR
CONSUMPTION

TECHNICAL INFORMATION*

BENEFITS OF USING THE RA-2 150 DF AIR KNIFE* (Compared to an open pipe)		Reduction in air consumption (%)		Noise reduction (%)		
		Up to 95%		Up to 32%		
PERFORMANCES AIR KNIFE RA-2 150 DF*	Pressure (bar)	Air consumption (l/min)	Blowing force (N)		Noise level (dB)	Amplified air (l/min)
			at 150mm	at 450mm		
	2	650	3,15	3	89	16250
	6	2100	11,8	10,5	95	52500
VS OPEN PIPE Ø8* (opened on 150mm)		Pressure (bar)	Air consumption (l/min)		Noise level (dB)	Amplified air (l/min)
		6	12000		130	12000

RA-2 150 DF AIR KNIFE FEATURES

- **Connection** : Female G3/8" • **Weight** : Aluminium : 575g • **Max. operating temperature** : Aluminium : 150°C • **Max pressure** : 10 bars

**AMPLIFIED AIRSTREAM
DEPENDING ON PRESSURE***

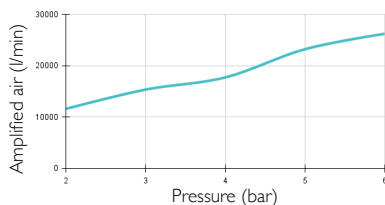

**BLOWING FORCE AT 150 MM
DEPENDING ON PRESSURE***

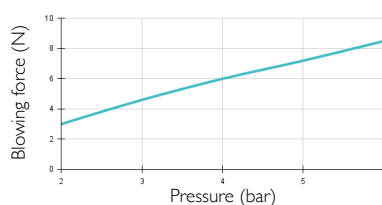

**BLOWING FORCE AT 450 MM
DEPENDING ON PRESSURE***

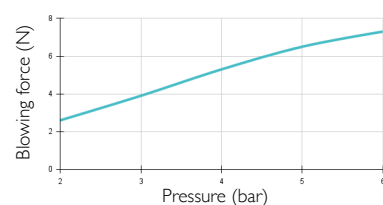

**AIR CONSUMPTION
DEPENDING ON PRESSURE***

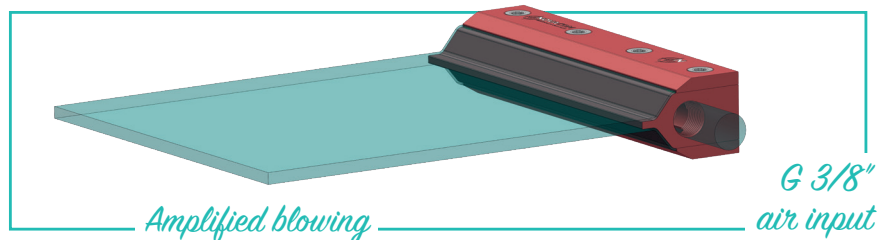
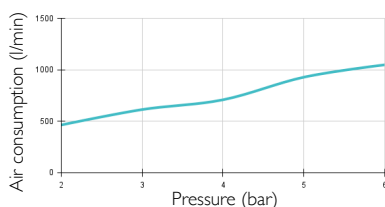

* **NOTE:** The measurements in this data sheet have been obtained in a laboratory under strict control. The varying conditions of a real industrial environment and the instability of pressure from an industrial compressor can create different values than the ones obtained in a laboratory. Those data are provided for information purposes only.
To achieve the best performance from the air knives, we recommend using a compressed air supply tube with a minimum 8 mm inside.

DIMENSIONS

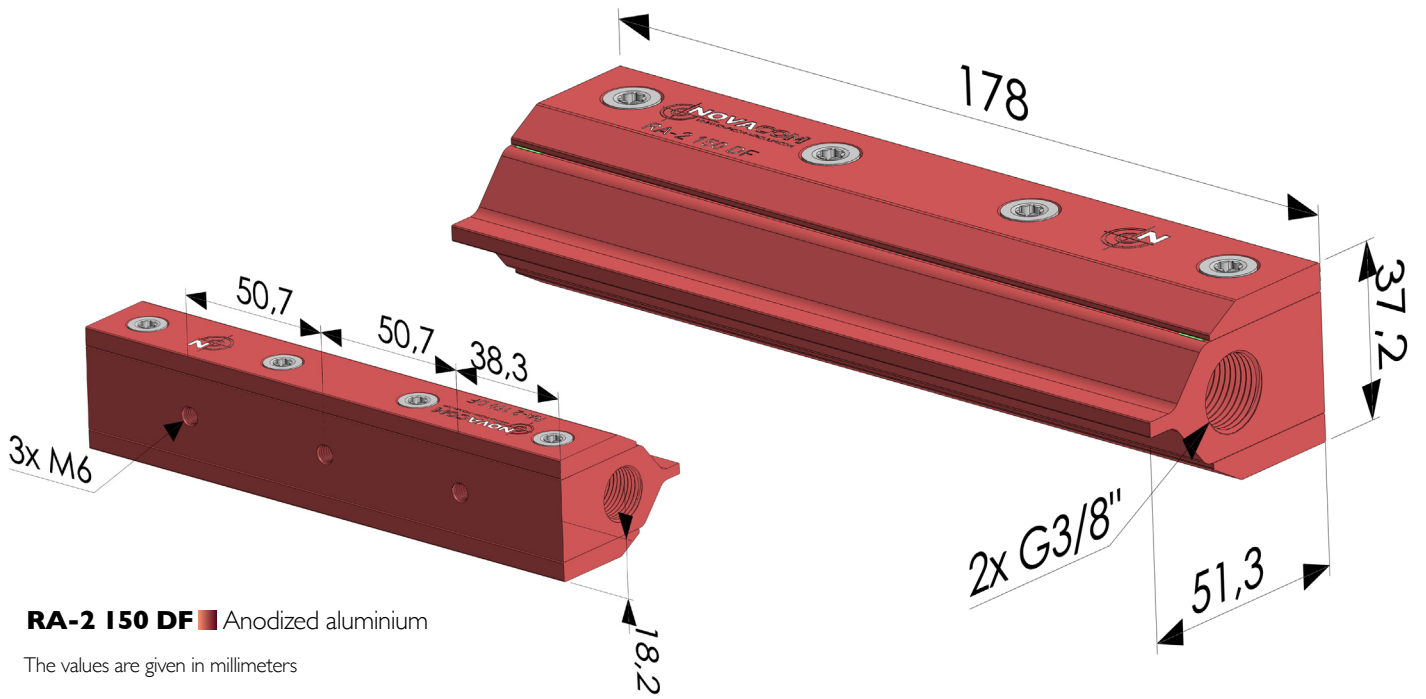

RA-2 150 DF ■ Anodized aluminium

The values are given in millimeters