

RAC-2 76

TECHNICAL SHEET

AIR KNIVES

CIRCULAR



OPERATING PRINCIPAL

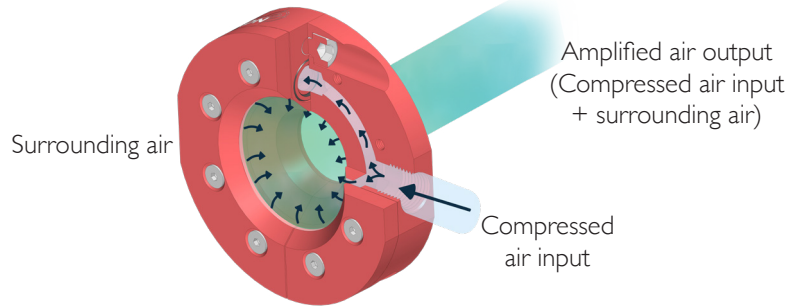

Economical

UP TO **-94%** SAVINGS IN AIR CONSUMPTION

TECHNICAL INFORMATION*

BENEFITS OF USING THE RAC-2 76 AIR KNIFE* (Compared to an open pipe)		Reduction in air consumption (%)		Noise reduction (%)		
		Up to 94%		Up to 35%		
PERFORMANCES AIR KNIFE RAC-2 76*	Pressure (bar)	Air consumption (l/min)	Blowing force (N)		Noise level (dB)	Amplified air (l/min)
			at 150mm	at 450mm		
	2	750	4,6	4,6	84	18750
	6	2150	20	19	90	53750
VS OPEN PIPE Ø8* (opened on 150mm)		Pressure (bar)	Air consumption (l/min)		Noise level (dB)	Amplified air (l/min)
		6	12000		130	12000

RAC-2 76 AIR KNIFE FEATURES

- **Connection** : Female G1/4" • **Weight** : Aluminium : 499g / Inox 316 L : 1 423g
- **Max. operating temperature** : Aluminium : 150°C / Inox 316 L : 450°C • **Max pressure** : 10 bars

AMPLIFIED AIRSTREAM
DEPENDING ON PRESSURE*

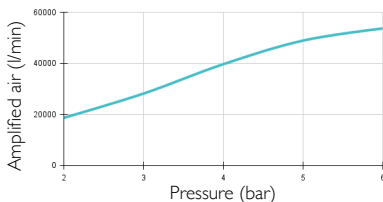

BLOWING FORCE AT 150 MM
DEPENDING ON PRESSURE*

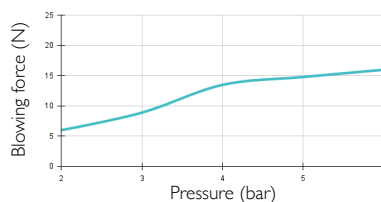

BLOWING FORCE AT 450 MM
DEPENDING ON PRESSURE*

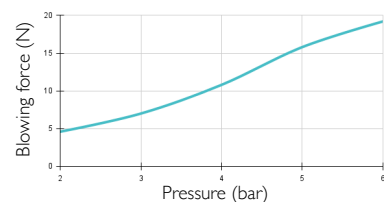

AIR CONSUMPTION
DEPENDING ON PRESSURE*

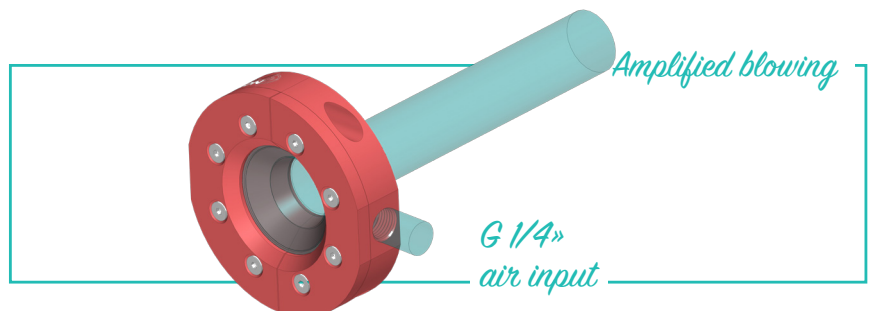
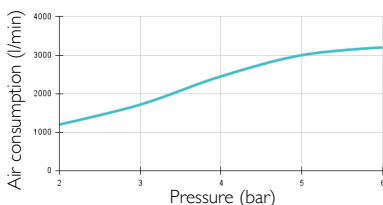

* **NOTE:** The measurements in this data sheet have been obtained in a laboratory under strict control. The varying conditions of a real industrial environment and the instability of pressure from an industrial compressor can create different values than the ones obtained in a laboratory. Those data are provided for information purposes only. To achieve the best performance from the air knives, we recommend using a compressed air supply tube with a minimum 8 mm inside diameter.

DIMENSIONS

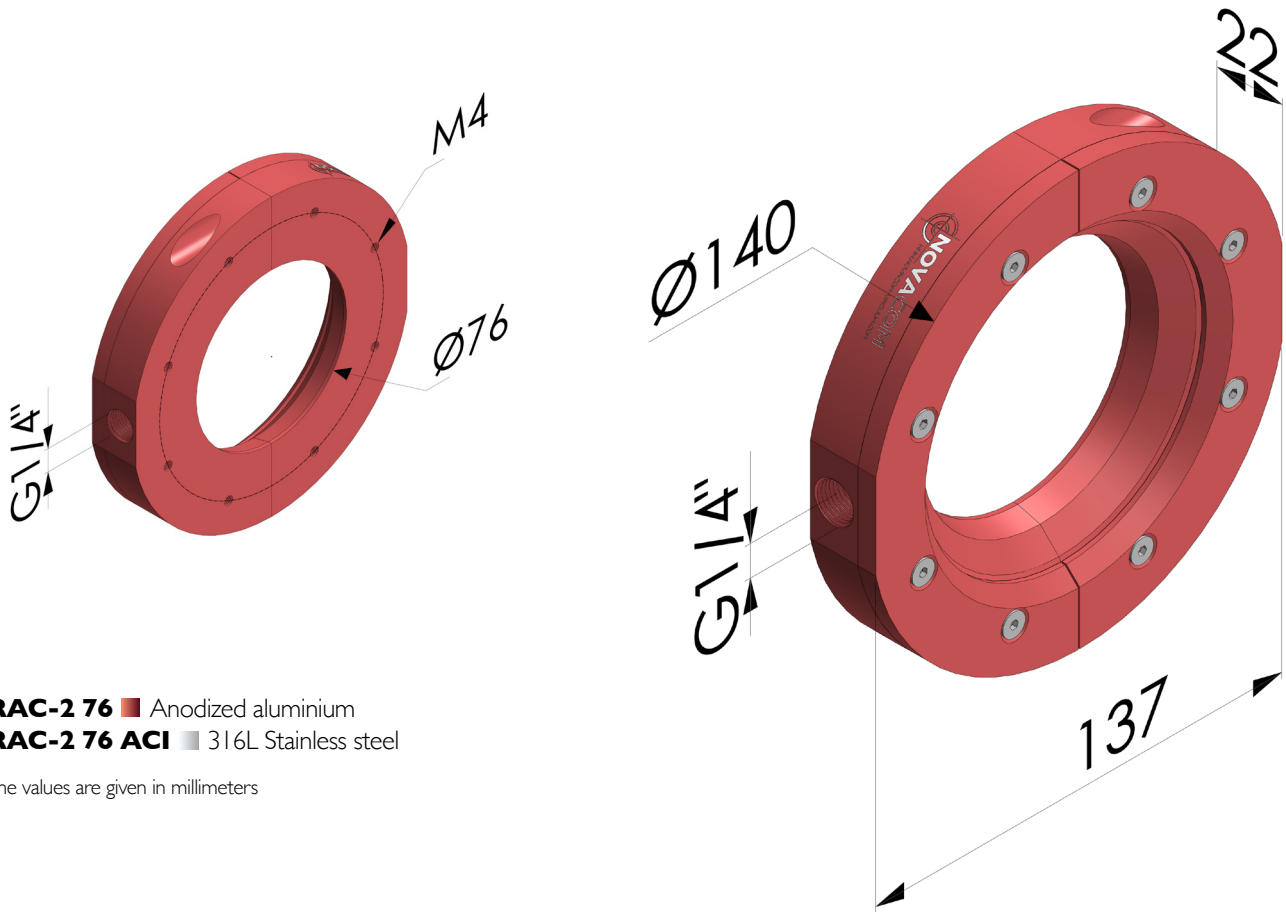

RAC-2 76 ■ Anodized aluminium
RAC-2 76 ACI ■ 316L Stainless steel

The values are given in millimeters