

CS 15

TECHNICAL SHEET

COLD AIR GUNS



OPERATING PRINCIPAL

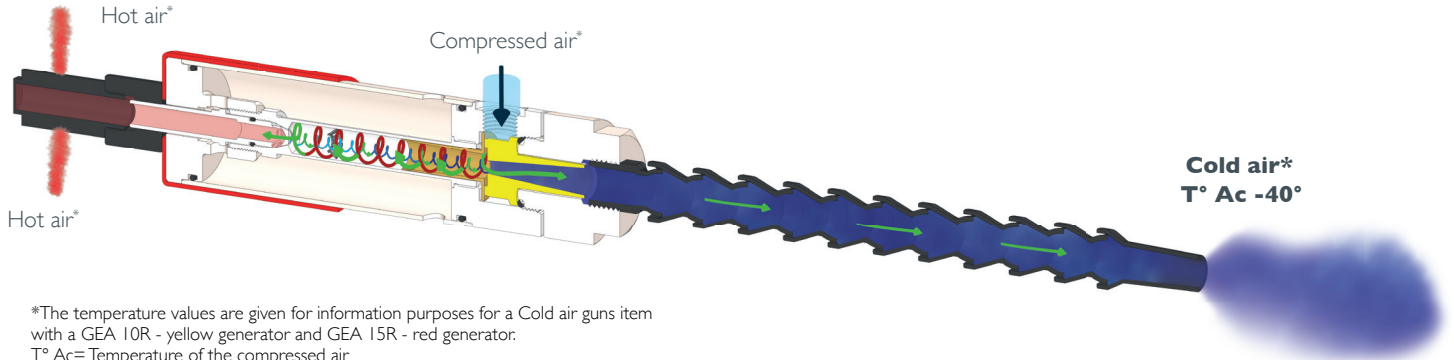

*The temperature values are given for information purposes for a Cold air guns item with a GEA 10R - yellow generator and GEA 15R - red generator.
T° Ac= Temperature of the compressed air



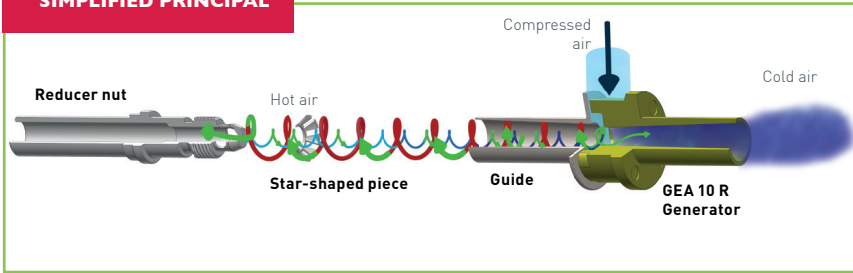

SIMPLIFIED PRINCIPAL

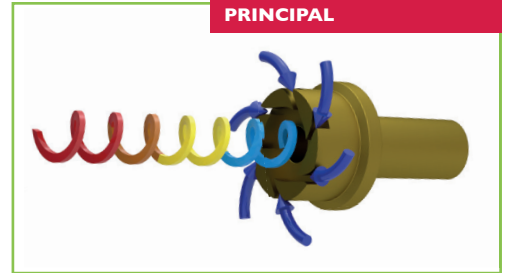

GENERATOR'S OPERATING PRINCIPAL



TECHNICAL INFORMATION

ITEM NUMBER	CONNECTION (GAZ)	GENERATORS	CONSUMED AIR (L/MN)		COOLING CAPACITY		AIR FLOW AT OUTLET (L/MIN)		BENEFITS	WEIGHT (G)	MATERIAL
			6 BARS	7 BARS	(KCAL/H)**	(BTU/H)	6 BARS	7 BARS			
CS15 R	G1/4"	GEA 10R 	430	430	95	376,99	115	152	One output	1458	Stainless steel
		GEA 15R 	495	495	135	535,72	152	170			
CS 15 YR		GEA 25R 	587	587	440	1746,06	205	285	Double output		
		GEA 35R 	786	786	720	2857,19	340	375			

RECOMMENDATIONS

- Recommended compressed air pressure 7bar

It is best not to use elbow fittings for the supply of compressed air on this product, you may



For optimal results, we recommend using an 8 mm inside diameter tube for Cold air guns CS10.

**The kilocalorie is an energy unit, a kilocalorie (equals 1000cal) represents the quantity of energy needed to reduce the temperature of 1 °C inside 1000 liters of water.

DIMENSIONS

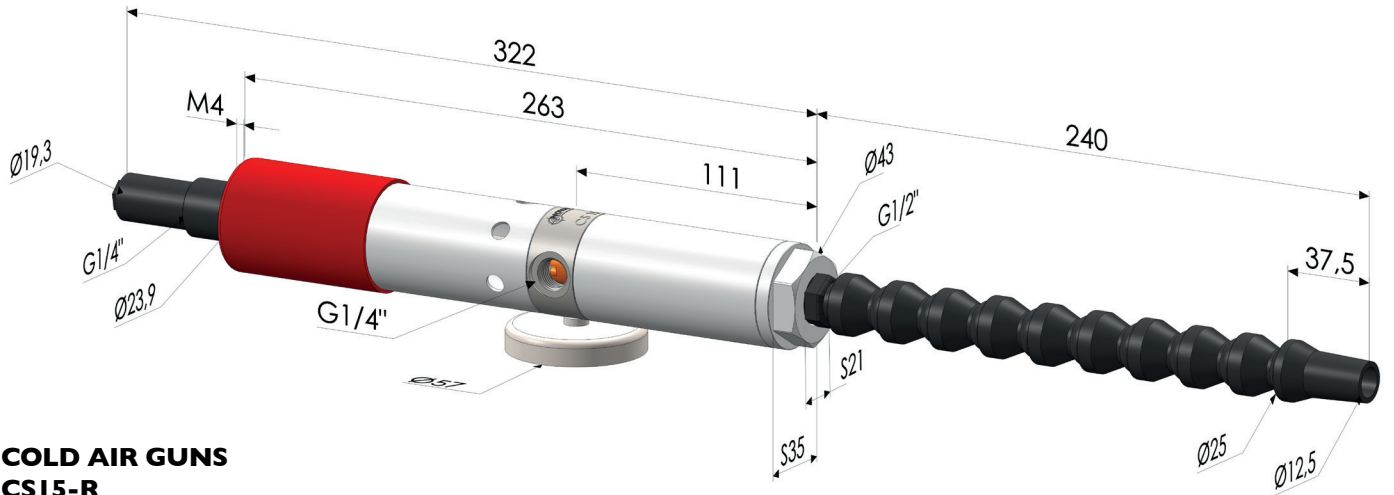

**COLD AIR GUNS
CSI5-R**

EN OPTION

**COLD AIR GUNS
CSI5-YR**

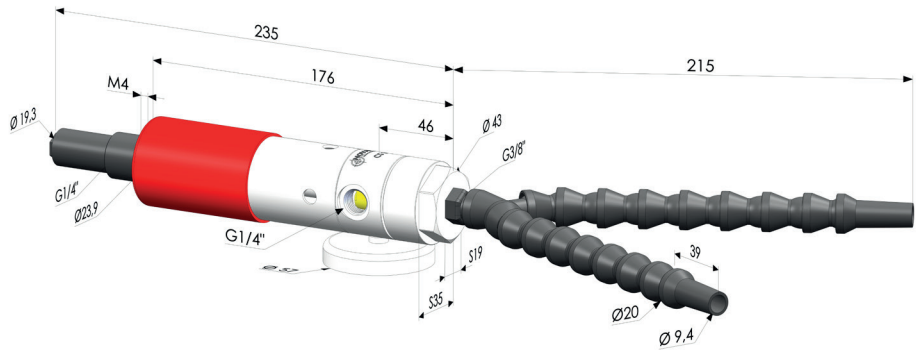

**COLD AIR GUNS
CSI5-TD**

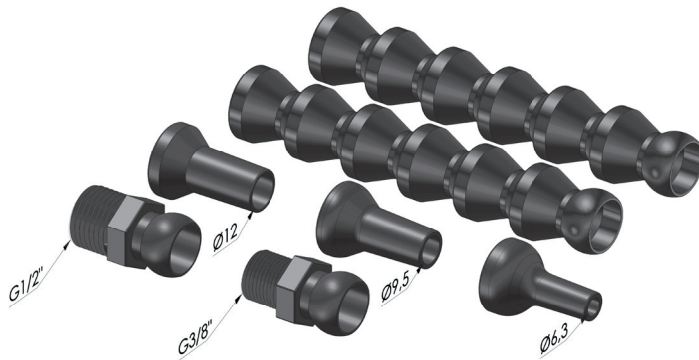
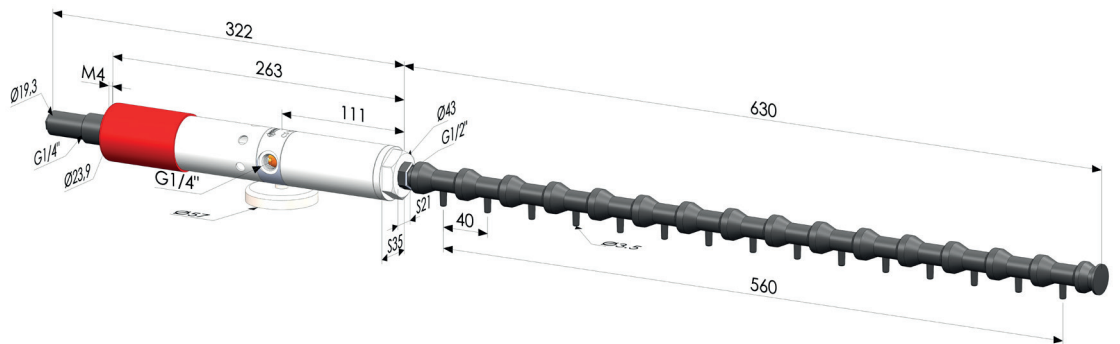

K01200 ■ POM

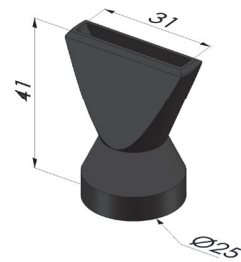

Q01200 ■ POM

ASSEMBLY PROCEDURE CS15 TECHNICAL SHEET COLD AIR GUNS

PROCEDURE TO FOLLOW

- A** Start by loosening the connector head (cold air outlet side). You can use a size 35 wrench.

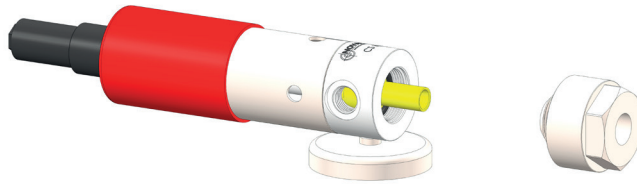

- B** Remove the vortex generator and the O-ring.

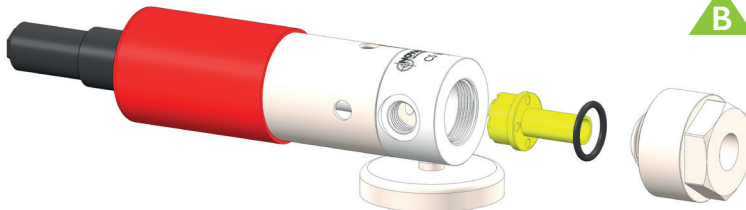

- C** Insert the new generator and make sure the blade shaped side of the generator is towards the hot air outlet.

Be sure to reposition the O-ring to its original location to ensure a perfect seal.

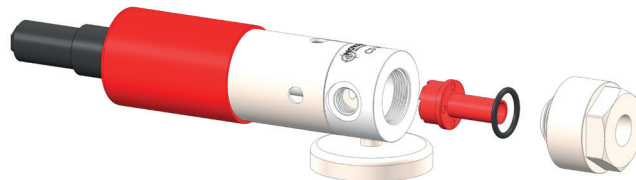

- D** Once the new generator is installed, you can screw the connector head back on. Make sure it is tightened properly to avoid any air leaks.

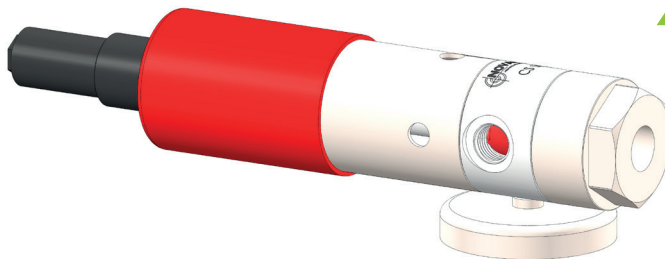

It is possible to adjust the hot air outlet control knob for better control of the cold air flow temperature. The more the hot air outlet knob is loosened, the colder the air at the outlet will be.

Test the cold air gun to ensure that the new generator is correctly installed and that the cold air temperature can be adjusted as expected. If you encounter problems during this test, it would be better to consult a qualified technician for assistance.