

VCR-2 250 14

TECHNICAL SHEET

SINGLE-STAGE EJECTOR

VCR-2 SERIES



OPERATING PRINCIPAL

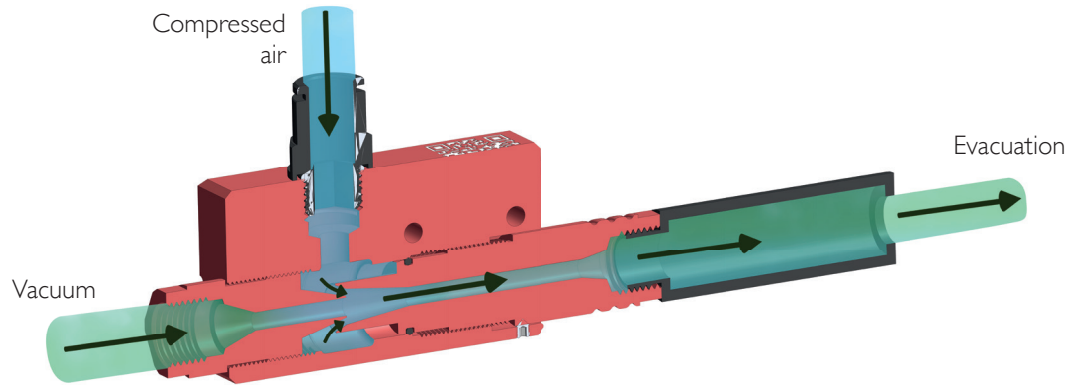

Vacuum

UP TO
85%
OF VACUUM

TECHNICAL INFORMATION*

BENEFITS OF USING A SINGLE-STAGE EJECTOR VCR-2 250 14*

Pressure (bar)	Air consumption (NI/mn)	Noise level (dB)	Vacuum level (%)	Suction rate (NI/min)
6	410	82	85	310

VCR-2 250 14* FEATURES

- **Connection** : Female G1/4" • **Weight** : Aluminium : 214 g - Stainless Steel 316L : 580g • **Max.Operating Temperature** : 80 °C
- **Max pressure** : 7 bar • **Materials** : Aluminium / Stainless Steel 316L, standard nitrile seal

AIR CONSUMPTION DEPENDING ON PRESSURE

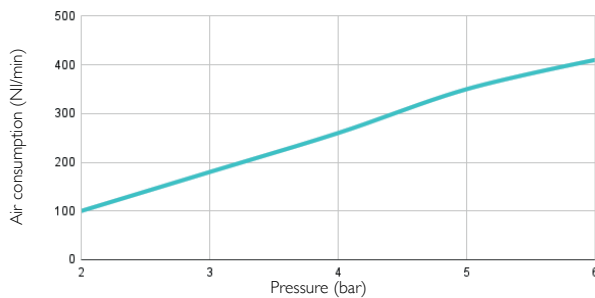

ASPIRATED AIR DEPENDING ON PRESSURE

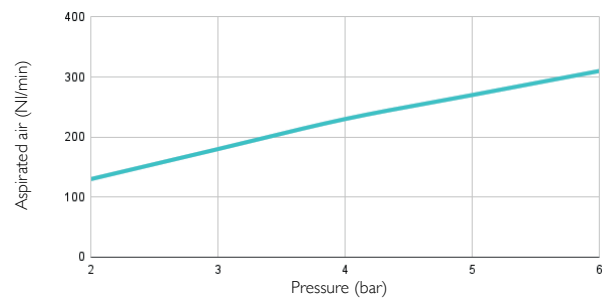

VACUUM LEVEL (%) DEPENDING ON PRESSURE

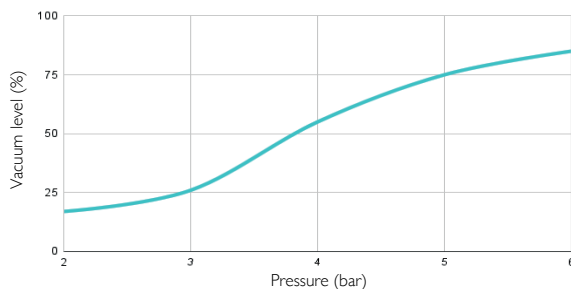

NOISE LEVEL DEPENDING ON PRESSURE

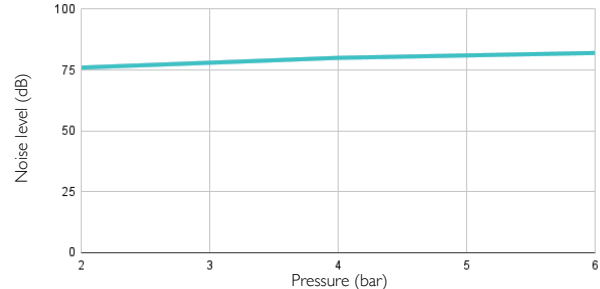

* **NOTE** : We recommend using a Ø8mm tube to supply the VCR-2 250 14, in order to obtain optimal performances.

DIMENSIONS

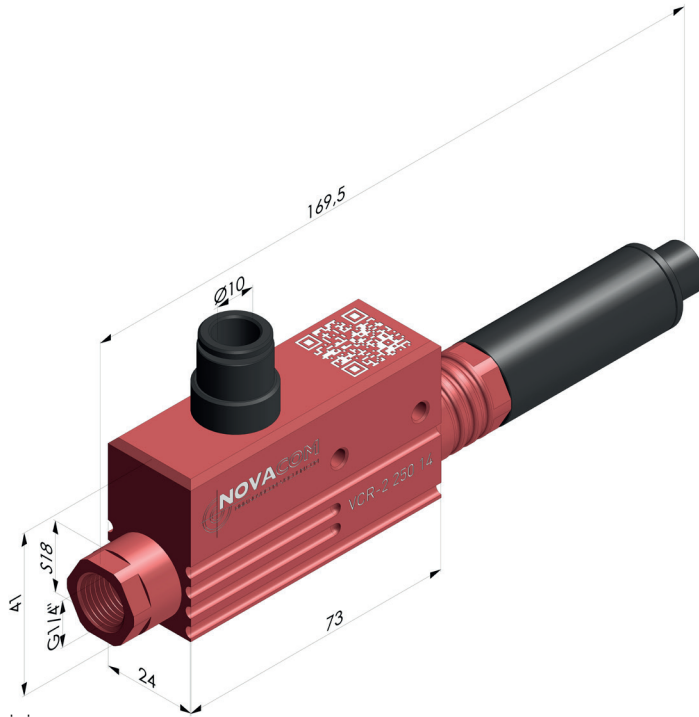

VCR-2 250 I4 ■ Aluminium

VCR-2 250 I4 ■ Stainless Steel 316L