

VCR-2 250 38

TECHNICAL SHEET

SINGLE-STAGE EJECTOR

VCR-2 SERIES



OPERATING PRINCIPAL

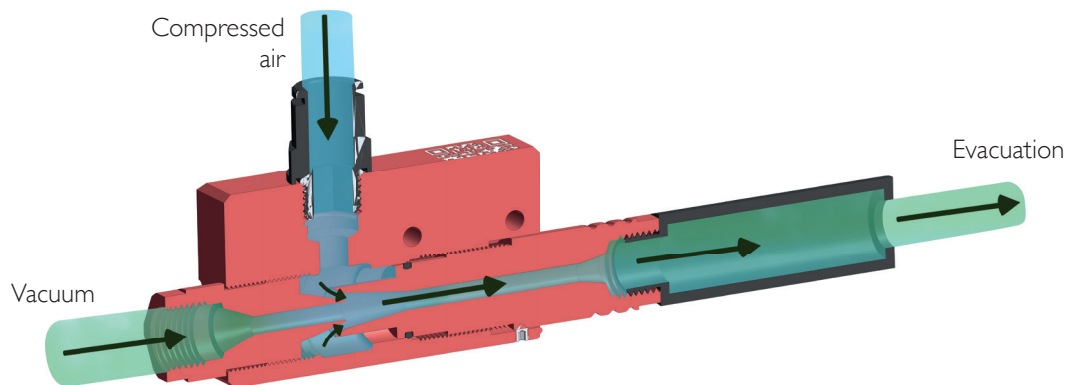

Vacuum

UP TO
85%
OF VACUUM

TECHNICAL INFORMATION*

BENEFITS OF USING A SINGLE-STAGE EJECTOR VCR-2 250 38*

Pressure (bar)	Air consumption (NI/mn)	Noise level (dB)	Vacuum level (%)	Suction rate (NI/min)
6	430	82	85	340

VCR-2 250 38* FEATURES

- **Connection :** Female G3/8" • **Weight :** Aluminium : 214 g • **Max.Operating Temperature :** Aluminium : 80 °C
- **Max pressure :** 7 bar • **Materials :** Aluminium, standard nitrile seal

AIR CONSUMPTION DEPENDING ON PRESSURE

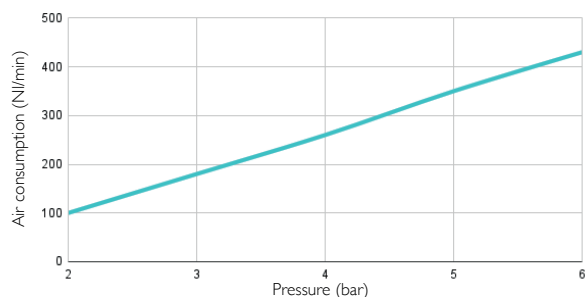

ASPIRATED AIR DEPENDING ON PRESSURE

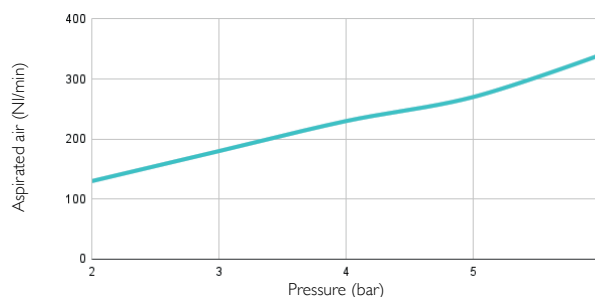

VACUUM LEVEL (%) DEPENDING ON PRESSURE

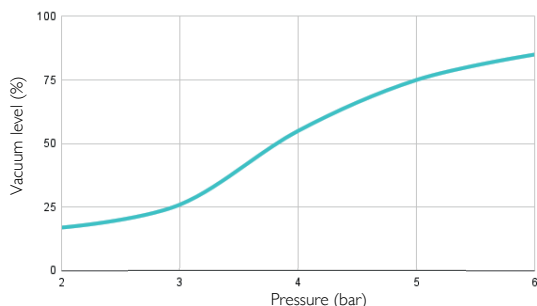

NOISE LEVEL DEPENDING ON PRESSURE

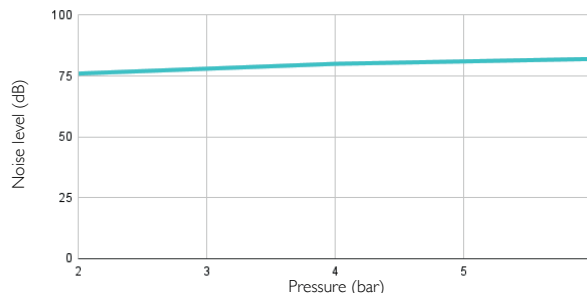

* **NOTE :** We recommend using a Ø8mm tube to supply the VCR-2 250 38, in order to obtain optimal performances.

DIMENSIONS

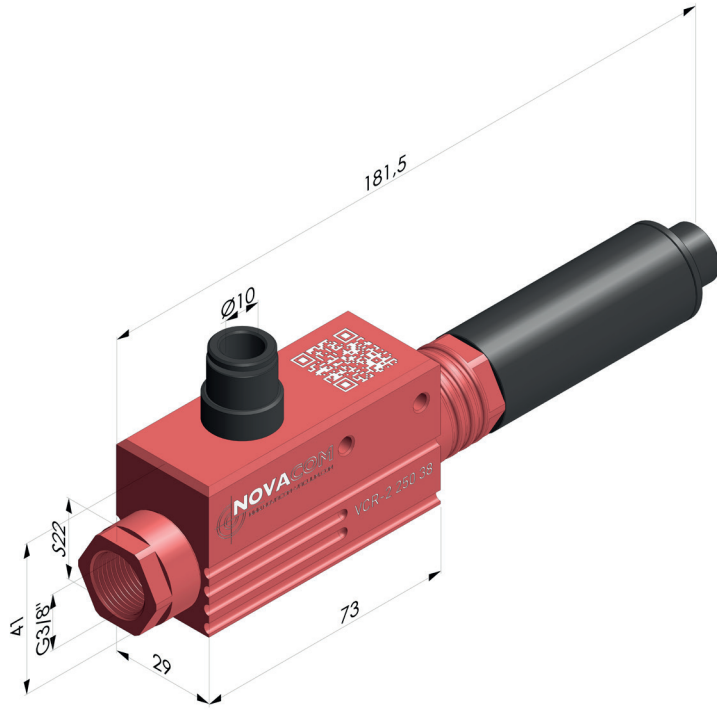

VCR-2 250 38 ■ Aluminium