

# VCR-2 150 14 EV

## TECHNICAL SHEET

### SINGLE-STAGE EJECTOR

### VCR-2 SERIES



#### OPERATING PRINCIPAL

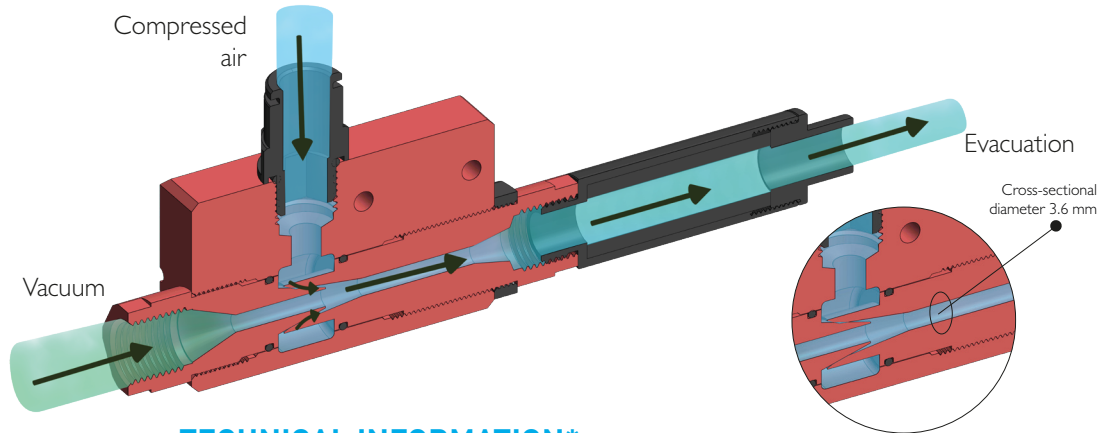

Vacuum

UP TO

# 85%

OF VACUUM

#### TECHNICAL INFORMATION\*

**BENEFITS OF USING SINGLE-STAGE EJECTOR VCR-2 150 14 EV\***

Pressure (bar)	Air consumption (NI/mn)	Noise level (dB)	Vacuum level (%)	Suction rate (NI/min)
6	120	82	85	110

#### VCR-2 150 14 EV\* FEATURES

- Connection : Female G1/4" • Weight : Aluminium : 214 g • Max.Operating Temperature : 60 °C
- Max pressure : 7 bar • Materials : Aluminium, standard nitrile seal

**AIR CONSUMPTION DEPENDING ON PRESSURE**

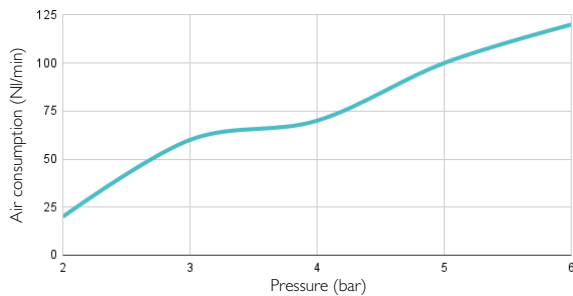

**ASPIRATED AIR DEPENDING ON PRESSURE**

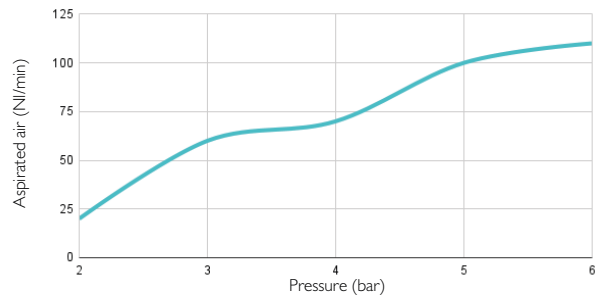

**VACUUM LEVEL (%) DEPENDING ON PRESSURE**

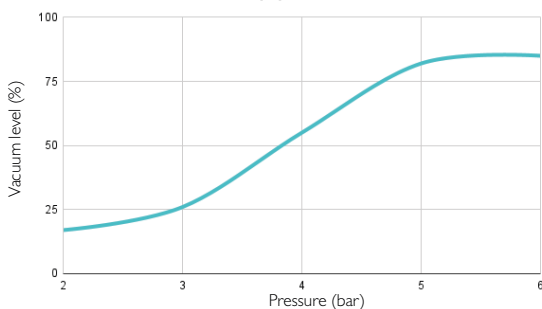

**NOISE LEVEL DEPENDING ON PRESSURE**

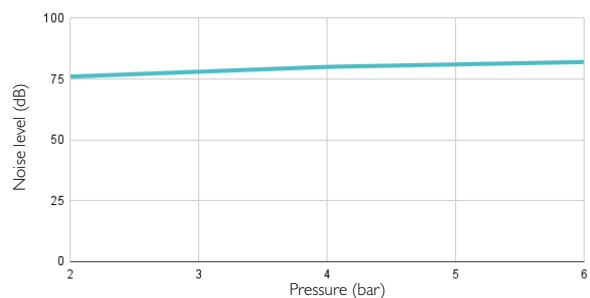

\* NOTE : We recommend using a Ø8mm tube to supply the VCR-2 150 14 EV, in order to obtain optimal performances.

## DIMENSIONS

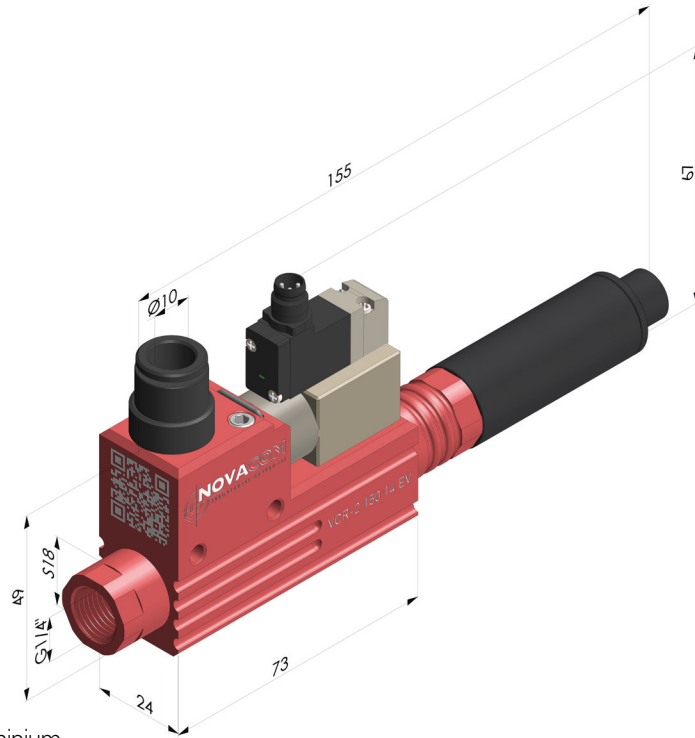

**VCR-2 150 I4 EV** ■ Aluminium

# TECHNICAL SHEET SOLENOID VALVE

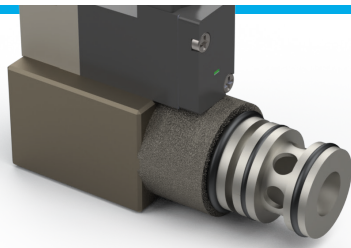

## DIMENSIONS

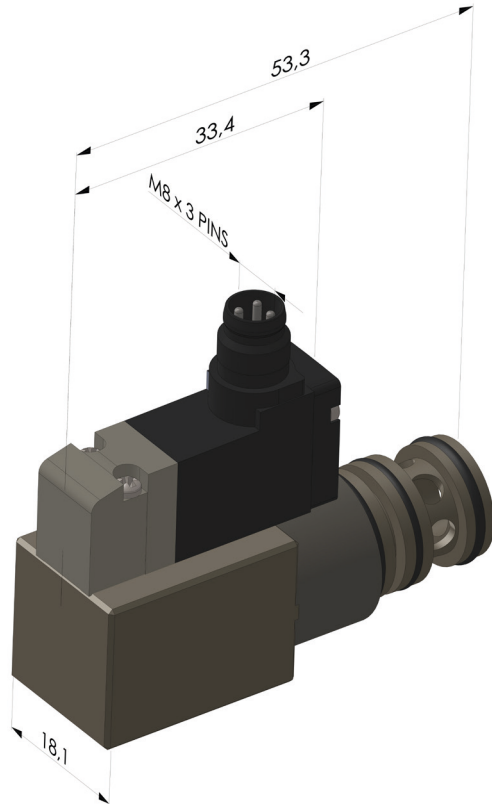

Body: brass  
Operator: technopolymer  
Spools: aluminium  
Seals: nitrile  
Pistons: aluminium  
Springs: spring steel

## WIRING DIAGRAM

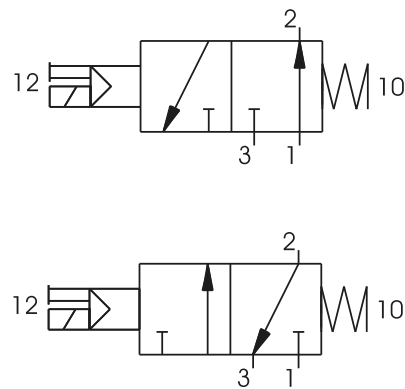

## TECHNICAL INFORMATION

ITEM NUMBER	FLUID	MAX. OPERATING PRESSURE (BAR)	OPERATING TEMPERATURE (°C)	FLOW AT 6 BAR WITH $\Delta P = 1$ (NL / MIN)	WEIGHT (G)	AVAILABLE VOLTAGE	CONNECTION TYPE	CYCLE COUNT	RESPONSE TIME	
									TURNING ON	TURNING OFF
EV 24VDC 1,2W	Filtered and lubricated air	7	-10 to +60 °C	700	18	24 VDC	PLUG IN M8 3 PIN - IP65 - Threaded fitting	50 000 000	12 ms	35 ms